



**1500L/2000L/
3000L/6000L**



**ARCTIC
FOX®**

Cryogenic Tanks

**COMPLETE
REFERENCE
GUIDE**

reliably
RATERMANN



1500L



2000L

Specifications	1500 Liter
Height (inches)	88.60
Foot Print (L x W) (inches)	63.00 x 63.00
Pallet base (L x W) (inches)	59.00 x 59.00
Empty Weight with pallet (pounds)	2,976
CAPACITY	
Liquid (Liters) Gross	1,500
Liquid (Liters) Net	1,290
Liquid (Gallons) Gross	396
Liquid (Gallons) Net	341
Gas capacity (ft ³) Nitrogen	29,470
Gas capacity (ft ³) Oxygen	36,338
Gas capacity (ft ³) Argon	35,561
Gas capacity (ft ³) Carbon Dioxide (CO ₂) *(1)	25,550
Capacity (Lbs) Carbon Dioxide (CO ₂) *(1)	2,923
PERFORMANCE	
NER (% /day LN ₂)	≤0.8%
NER (Lb/day) Carbon Dioxide (CO ₂)	≤2.8
Gas Flow (scfh) N ₂ , O ₂ , Ar	2,471
Gas Flow (scfh) Carbon Dioxide (CO ₂) *(1)	927
Gas Flow (Lb/hr) Carbon Dioxide (CO ₂) *(1)	113
PRESSURE RATINGS	
Max. Pressure relief setting (psig)	500
Operating Pressure (psig)	450
Design Specification	ASME VIII-1
*(1) Bulk (CO ₂) Package Required: Package includes bulk CO ₂ flange and bulk CO ₂ CGA inlet, Orange Research gauge with Buna seals	
<i>All specifications are subject to change without prior notice. All dimensions are measured from the floor to the top of the tank.</i>	

Specifications	2000 Liter
Height (inches)	115.00
Foot Print (L x W) (inches)	63.00 x 63.00
Pallet base (L x W) (inches)	59.00 x 59.00
Empty Weight with pallet (pounds)	3,401
CAPACITY	
Liquid (Liters) Gross	2,080
Liquid (Liters) Net	1,830
Liquid (Gallons) Gross	550
Liquid (Gallons) Net	483
Gas capacity (ft ³) Nitrogen	41,806
Gas capacity (ft ³) Oxygen	51,549
Gas capacity (ft ³) Argon	50,447
Gas capacity (ft ³) Carbon Dioxide (CO ₂) *(1)	36,245
Capacity (Lbs) Carbon Dioxide (CO ₂) *(1)	4,416
PERFORMANCE	
NER (% /day LN ₂)	≤0.8%
NER (Lb/day) Carbon Dioxide (CO ₂)	≤3.8
Gas Flow (scfh) N ₂ , O ₂ , Ar	2,825
Gas Flow (scfh) Carbon Dioxide (CO ₂) *(1)	1,060
Gas Flow (Lb/hr) Carbon Dioxide (CO ₂) *(1)	130
PRESSURE RATINGS	
Max. Pressure relief setting (psig)	500
Operating Pressure (psig)	450
Design Specification	ASME VIII-1
*(1) Bulk (CO ₂) Package Required: Package includes bulk CO ₂ flange and bulk CO ₂ CGA inlet, Orange Research gauge with Buna seals	
<i>All specifications are subject to change without prior notice. All dimensions are measured from the floor to the top of the tank.</i>	



3000L

Specifications

	3000 Liter
Height (inches)	121.00
Foot Print (L x W) (inches)	75.00 x 75.00
Pallet base (L x W) (inches)	66.00 x 66.00
Empty Weight with pallet (pounds)	4,404

CAPACITY

Liquid (Liters) Gross	3,000
Liquid (Liters) Net	2,580
Liquid (Gallons) Gross	793
Liquid (Gallons) Net	682
Gas capacity (ft ³) Nitrogen	58,940
Gas capacity (ft ³) Oxygen	72,677
Gas capacity (ft ³) Argon	71,123
Gas capacity (ft ³) Carbon Dioxide (CO ₂) *(1)	51,099
Capacity (Lbs) Carbon Dioxide (CO ₂) *(1)	5,846

PERFORMANCE

NER (% /day LN ₂)	≤0.8%
NER (Lb/day) Carbon Dioxide (CO ₂)	≤4.0
Gas Flow (scfh) N ₂ , O ₂ , Ar	2,825
Gas Flow (scfh) Carbon Dioxide (CO ₂) *(1)	1,060
Gas Flow (Lb/hr) Carbon Dioxide (CO ₂) *(1)	130

PRESSURE RATINGS

Max. Pressure relief setting (psig)	500
Operating Pressure (psig)	450
Design Specification	ASME VIII-1

*(1) Bulk (CO₂) Package Required: Package includes bulk CO₂ flange and bulk CO₂ CGA inlet, Orange Research gauge with Buna seals

*All specifications are subject to change without prior notice.
All dimensions are measured from the floor to the top of the tank.*



6000L

Specifications

	6000 Liter
Height (inches)	130.00
Foot Print (L x W) (inches)	112.00 x 112.00
Pallet base (L x W) (inches)	94.50 x 94.50
Empty Weight with pallet (pounds)	9,480

CAPACITY

Liquid (Liters) Gross	6,000
Liquid (Liters) Net	5,400
Liquid (Gallons) Gross	1,585
Liquid (Gallons) Net	1,426
Gas capacity (ft ³) Nitrogen	123,362
Gas capacity (ft ³) Oxygen	152,112
Gas capacity (ft ³) Argon	148,860
Gas capacity (ft ³) Carbon Dioxide (CO ₂) *(1)	106,953
Capacity (Lbs) Carbon Dioxide (CO ₂) *(1)	12,236

PERFORMANCE

NER (% /day LN ₂)	≤0.45%
NER (Lb/day) Carbon Dioxide (CO ₂)	≤5.6
Gas Flow (scfh) N ₂ , O ₂ , Ar	3,531
Gas Flow (scfh) Carbon Dioxide (CO ₂) *(1)	1,900
Gas Flow (Lb/hr) Carbon Dioxide (CO ₂) *(1)	218

PRESSURE RATINGS

Max. Pressure relief setting (psig)	500
Operating Pressure (psig)	450
Design Specification	ASME VIII-1

*(1) Bulk (CO₂) Package Required: Package includes bulk CO₂ flange and bulk CO₂ CGA inlet, Orange Research gauge with Buna seals

*All specifications are subject to change without prior notice.
All dimensions are measured from the floor to the top of the tank.*

ARCTIC FOX[®] TANK FEATURES

**ALL STAINLESS STEEL, MIRROR FINISH
CONSTRUCTION.**



**Stainless Steel. Mirror
Finish**



DV6R Vacuum Probe
Easily check the tanks vacuum.



Built In Vaporizer
Robust gas use vaporizer



**Pressure Building
Vaporizer**



Top & Bottom Fill
Top and bottom fill capabilities



Content Gauges
Easy to read gauges, isolation
valves, includes convenient
mounting plate.



Herose Divertor Valve
With redundant 1/2" ASME relief
valves with pipeaway and burst
disc.

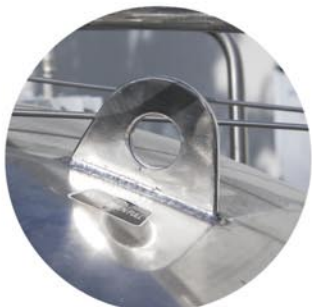

Lifting Lugs



1" Auxiliary Liquid Port



Galvanized Pallet Tank
Tank Base designed with built in
forking slots, access holes for
bolting tank down, galvanized for
long life and protection from rust.

ARCTIC FOX® TOP & BOTTOM FILL TANK FEATURES

Mirror Finish
No Painting Ever Needed

Easy to read
full/empty pressure
differential gauge.

TELEMETRY READY
PLUMBING
Convenient removable
mounting plate is
also provided

EQUIPPED WITH
BOTTOM FILL –
Keep pressure up while
allowing no interruption
to gas supply

TOP FILL –
To help drop head
pressure when filling

FILL CONNECTOR –
Includes Bulk Connection

Galvanized Skid

1" NPT Bottom
Port For Liquid
Withdrawal

DV6R
Vacuum
Probe

ARCTIC
FOX
Cryogenic Tanks

The Arctic Fox®
6000L tank comes
equipped standard
with top and
bottom fill valves:

The benefits of a tank with top and bottom fill valves is that the customer does not have to be taken offline to have the tank refilled. Designed for applications in medical and laser cutting where a large drop in downstream pressure would cause problems. The driver can now maintain the filling pressure by opening the top and bottom fill valves simultaneously to keep the pressure up while not allowing any interruptions to the gas supply.

Auxiliary Blow Down
Vent Valve

DIVERTOR VALVE –
Herose divertor
valve with
redundant ASME
1/2" x 1"
pressure reliefs.

Heavy duty pressure
building regulator

Watch the
Video



For more information and videos go to
rmi.rmimfg.com/arctic-fox-tanks

Features of the 1,500 Liter Series Arctic Fox®

1500
Liter

DV6R Vacuum Probe	✓
Top fill capability with Micro bulk CGA connection	✓
Top/Bottom bulk fill connection w/inline checks & oversized plumbing for rapid fill times.	☐
High gas output capacity	✓
Excellent NER and product retention	✓
External Pressure building system for rapid recovery	✓
Vaporizer with high volume gas output capability included	✓
Isolation valves for all components for field repairs with minimal product loss.	✓
2" Pressure gauge and 3 1/2" easy to read Liquid level gauge	✓
Port for testing annular vacuum levels	✓
VHP (500 psi) gas service with other service pressures available	✓
Strainer protected PB Regulator	✓
Liquid withdraw options	✓
Mounting provisions for your telemetry unit	✓
Dual vent lines for rapid blow down capability	✓
Dual 1/2" x 1" safeties with Heavy Duty divertor valve	✓
Small footprint galvanized skid included	✓
5 Year warranty on the vacuum	✓
1 year parts and labor	✓

**ARCTIC
FOX®**
Cryogenic Tanks

**1,500
LITER**

**DATA
SHEET**

1,500 Liter
Mini Bulk,
VHP500

Part #
MBK-1500VHPL



Specifications

1500
Liter

Height (inches)	88.60
Foot Print (L x W) (inches)	63.00 x 63.00
Pallet base (L x W) (inches)	59.00 x 59.00
Empty Weight with pallet (pounds)	2,976

CAPACITY

Liquid (Liters) Gross	1,500
Liquid (Liters) Net	1,290
Liquid (Gallons) Gross	396
Liquid (Gallons) Net	341
Gas capacity (ft³) Nitrogen	29,470
Gas capacity (ft³) Oxygen	36,338
Gas capacity (ft³) Argon	35,561
Gas capacity (ft³) Carbon Dioxide (CO ₂) *(1)	25,550
Capacity (Lbs) Carbon Dioxide (CO ₂) *(1)	2,923

PERFORMANCE

NER (% /day LN ₂)	≤0.8%
NER (Lb/day) Carbon Dioxide (CO ₂)	≤2.8
Gas Flow (scfh) N ₂ , O ₂ , Ar	2,471
Gas Flow (scfh) Carbon Dioxide (CO ₂) *(1)	927
Gas Flow (Lb/hr) Carbon Dioxide (CO ₂) *(1)	113

PRESSURE RATINGS

Max. Pressure relief setting (psig)	500
Operating Pressure (psig)	450
Design Specification	ASME VIII-1

*(1) Bulk (CO₂) Package Required: Package includes bulk CO₂ flange and bulk CO₂ CGA inlet, Orange Research gauge with Buna seals

*All specifications are subject to change without prior notice.
All dimensions are measured from the floor to the top of the tank.*

1,500L VHP Flow Chart

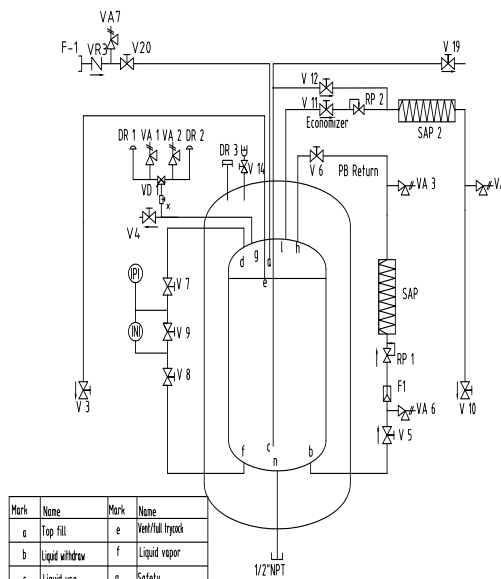

Mark	Name	Mark	Name
a	Top fill	e	Vent/Fill Inpack
b	Liquid withdraw	f	Liquid vapor
c	Liquid use	g	Safety
d	Gas vapor	h	PB out
i	Economizer	n	Liquid reserve

- Certification for medical Oxygen is available as an added option.
- CO₂ packages are available as an added option.

*Please contact
Ratermann
Mfg., Inc.
for
additional
information.*

Features of the 2,000 Liter Series Arctic Fox®

2000
Liter

DV6R Vacuum Probe	✓
Top fill capability with Micro bulk CGA connection	✓
Top/Bottom bulk fill connection w/inline checks & oversized plumbing for rapid fill times.	✓
High gas output capacity	✓
Excellent NER and product retention	✓
External Pressure building system for rapid recovery	✓
Vaporizer with high volume gas output capability included	✓
Isolation valves for all components for field repairs with minimal product loss.	✓
2" Pressure gauge and 3 1/2" easy to read Liquid level gauge	✓
Port for testing annular vacuum levels	✓
VHP (500 psi) gas service with other service pressures available	✓
Strainer protected PB Regulator	✓
Liquid withdraw options	✓
Mounting provisions for your telemetry unit	✓
Dual vent lines for rapid blow down capability	✓
Dual 1/2" x 1" safeties with Heavy Duty divertor valve	✓
Small footprint galvanized skid included	✓
5 Year warranty on the vacuum	✓
1 year parts and labor	✓

**ARCTIC
FOX**
Cryogenic Tanks

**2,000
LITER**

**DATA
SHEET**

2,000 Liter
Mini Bulk,
VHP500

Part #
MBK-2000VHPL



Specifications

2000
Liter

Height (inches)	115.00
Foot Print (L x W) (inches)	63.00 x 63.00
Pallet base (L x W) (inches)	59.00 x 59.00
Empty Weight with pallet (pounds)	3,401

CAPACITY

Liquid (Liters) Gross	2,080
Liquid (Liters) Net	1,830
Liquid (Gallons) Gross	550
Liquid (Gallons) Net	483
Gas capacity (ft ³) Nitrogen	41,806
Gas capacity (ft ³) Oxygen	51,549
Gas capacity (ft ³) Argon	50,447
Gas capacity (ft ³) Carbon Dioxide (CO ₂) *(1)	36,245
Capacity (Lbs) Carbon Dioxide (CO ₂) *(1)	4,416

PERFORMANCE

NER (% /day LN ₂)	≤0.8%
NER (Lb/day) Carbon Dioxide (CO ₂)	≤3.8
Gas Flow (scfh) N ₂ , O ₂ , Ar	2,825
Gas Flow (scfh) Carbon Dioxide (CO ₂) *(1)	1,060
Gas Flow (Lb/hr) Carbon Dioxide (CO ₂) *(1)	130

PRESSURE RATINGS

Max. Pressure relief setting (psig)	500
Operating Pressure (psig)	450
Design Specification	ASME VIII-1

*(1) Bulk (CO₂) Package Required: Package includes bulk CO₂ flange and bulk CO₂ CGA inlet, Orange Research gauge with Buna seals

*All specifications are subject to change without prior notice.
All dimensions are measured from the floor to the top of the tank.*

2,000L VHP Flow Chart

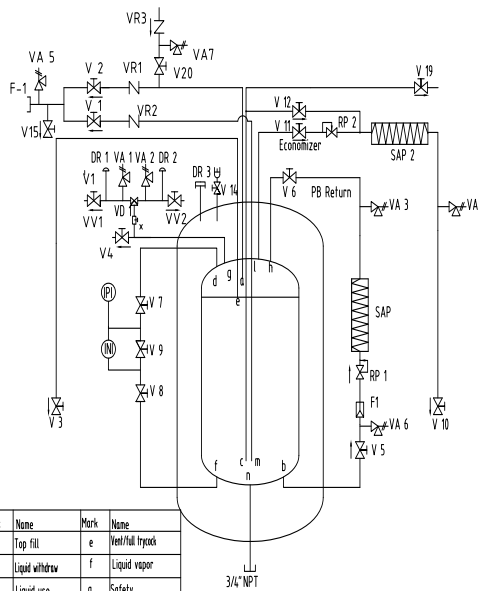

Mark	Name	Mark	Name
a	Top fill	e	Vent/Fill Inport
b	Liquid withdraw	f	Liquid vapor
c	Liquid use	g	Safety
d	Gas vapor	h	PB out
i	Economizer	n	Liquid reserve
m	Bottom fill		

- Certification for medical Oxygen is available as an added option.
- CO₂ packages are available as an added option.

*Please contact
Ratermann
Mfg., Inc.
for
additional
information.*

Features of the 3,000 Liter Series Arctic Fox®

3000
Liter

DV6R Vacuum Probe	✓
Top fill capability with Micro bulk CGA connection	✓
Top/Bottom bulk fill connection w/inline checks & oversized plumbing for rapid fill times.	✓
High gas output capacity	✓
Excellent NER and product retention	✓
External Pressure building system for rapid recovery	✓
Vaporizer with high volume gas output capability included	✓
Isolation valves for all components for field repairs with minimal product loss.	✓
2" Pressure gauge and 3 1/2" easy to read Liquid level gauge	✓
Port for testing annular vacuum levels	✓
VHP (500 psi) gas service with other service pressures available	✓
Strainer protected PB Regulator	✓
Liquid withdraw options	✓
Mounting provisions for your telemetry unit	✓
Dual vent lines for rapid blow down capability	✓
Dual 1/2" x 1" safeties with Heavy Duty divertor valve	✓
Small footprint galvanized skid included	✓
5 Year warranty on the vacuum	✓
1 year parts and labor	✓

**ARCTIC
FOX**
Cryogenic Tanks

**3,000
LITER**

**DATA
SHEET**

3,000 Liter
Mini Bulk,
VHP500
Part #
MBK-3000VHPL



Specifications

3000
Liter

Height (inches)	121.00
Foot Print (L x W) (inches)	75.00 x 75.00
Pallet base (L x W) (inches)	66.00 x 66.00
Empty Weight with pallet (pounds)	4,404

CAPACITY

Liquid (Liters) Gross	3,000
Liquid (Liters) Net	2,580
Liquid (Gallons) Gross	793
Liquid (Gallons) Net	682
Gas capacity (ft³) Nitrogen	58,940
Gas capacity (ft³) Oxygen	72,677
Gas capacity (ft³) Argon	71,123
Gas capacity (ft³) Carbon Dioxide (CO₂) *(1)	51,099
Capacity (Lbs) Carbon Dioxide (CO₂) *(1)	5,846

PERFORMANCE

NER (% /day LN₂)	≤0.8%
NER (Lb/day) Carbon Dioxide (CO₂)	≤4.0
Gas Flow (scfh) N₂, O₂, Ar	2,825
Gas Flow (scfh) Carbon Dioxide (CO₂) *(1)	1,060
Gas Flow (Lb/hr) Carbon Dioxide (CO₂) *(1)	130

PRESSURE RATINGS

Max. Pressure relief setting (psig)	500
Operating Pressure (psig)	450
Design Specification	ASME VIII-1

*(1) Bulk (CO₂) Package Required: Package includes bulk CO₂ flange and bulk CO₂ CGA inlet, Orange Research gauge with Buna seals

All specifications are subject to change without prior notice.
All dimensions are measured from the floor to the top of the tank.

3,000L VHP Flow Chart

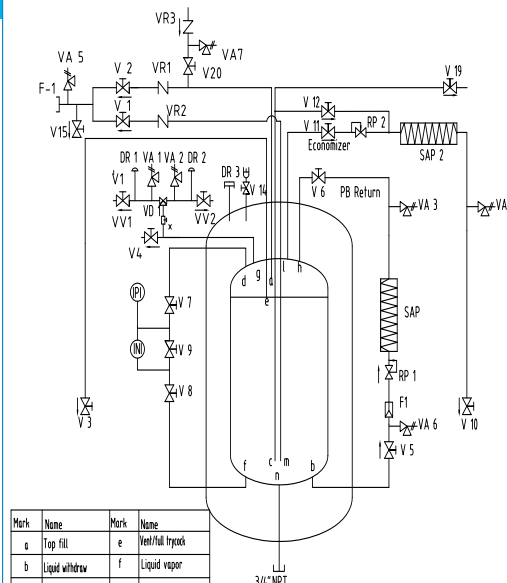

Mark	Name	Mark	Name
a	Top fill	e	Vent/Full topup
b	Liquid withdraw	f	Liquid vapor
c	Liquid use	g	Safety
d	Gas vapor	h	PB out
i	Economizer	n	Liquid reserve
m	Bottom fill		

- Certification for medical Oxygen is available as an added option.
- CO2 packages are available as an added option.

Please contact
**Ratermann
Mfg., Inc.**
for
additional
information.

Features of the 6,000 Liter Series Arctic Fox®	6000 Liter
DV6R Vacuum Probe	<input checked="" type="checkbox"/>
Top fill capability with Micro bulk CGA connection	<input type="checkbox"/>
Top/Bottom bulk fill connection w/inline checks & oversized plumbing for rapid fill times.	<input checked="" type="checkbox"/>
High gas output capacity	<input checked="" type="checkbox"/>
Excellent NER and product retention	<input checked="" type="checkbox"/>
External Pressure building system for rapid recovery	<input checked="" type="checkbox"/>
Vaporizer with high volume gas output capability included	<input checked="" type="checkbox"/>
Isolation valves for all components for field repairs with minimal product loss.	<input checked="" type="checkbox"/>
2" Pressure gauge and 3 1/2" easy to read Liquid level gauge	<input checked="" type="checkbox"/>
Port for testing annular vacuum levels	<input checked="" type="checkbox"/>
VHP (500 psi) gas service with other service pressures available	<input checked="" type="checkbox"/>
Strainer protected PB Regulator	<input checked="" type="checkbox"/>
Liquid withdraw options	<input checked="" type="checkbox"/>
Mounting provisions for your telemetry unit	<input checked="" type="checkbox"/>
Dual vent lines for rapid blow down capability	<input checked="" type="checkbox"/>
Dual 1/2" x 1" safeties with Heavy Duty divertor valve	<input checked="" type="checkbox"/>
Small footprint galvanized skid included	<input checked="" type="checkbox"/>
5 Year warranty on the vacuum	<input checked="" type="checkbox"/>
1 year parts and labor	<input checked="" type="checkbox"/>

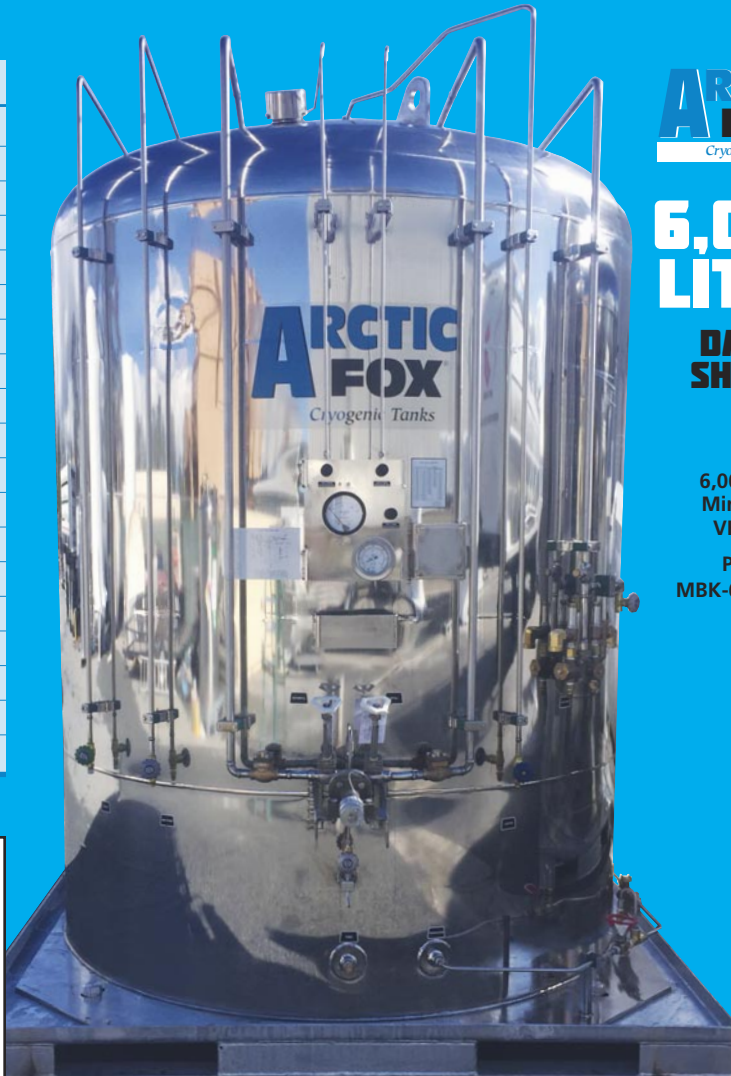

ARCTIC FOX
Cryogenic Tanks

6,000 LITER

DATA SHEET

6,000 Liter
Mini Bulk,
VHP500

Part #
MBK-6000VHPL

Specifications

	6000 Liter
Height (inches)	130.00
Foot Print (L x W) (inches)	112.00 x 112.00
Pallet base (L x W) (inches)	94.50 x 94.50
Empty Weight with pallet (pounds)	9,480

CAPACITY

Liquid (Liters) Gross	6,000
Liquid (Liters) Net	5,400
Liquid (Gallons) Gross	1,585
Liquid (Gallons) Net	1,426
Gas capacity (ft ³) Nitrogen	123,362
Gas capacity (ft ³) Oxygen	152,112
Gas capacity (ft ³) Argon	148,860
Gas capacity (ft ³) Carbon Dioxide (CO ₂) *(1)	106,953
Capacity (Lbs) Carbon Dioxide (CO ₂) *(1)	12,236

PERFORMANCE

NER (% /day LN ₂)	≤0.45%
NER (Lb/day) Carbon Dioxide (CO ₂)	≤5.6
Gas Flow (scfh) N ₂ , O ₂ , Ar	3,531
Gas Flow (scfh) Carbon Dioxide (CO ₂) *(1)	1,900
Gas Flow (Lb/hr) Carbon Dioxide (CO ₂) *(1)	218

PRESSURE RATINGS

Max. Pressure relief setting (psig)	500
Operating Pressure (psig)	450
Design Specification	ASME VIII-1

*(1) Bulk (CO₂) Package Required: Package includes bulk CO₂ flange and bulk CO₂ CGA inlet, Orange Research gauge with Buna seals

All specifications are subject to change without prior notice.
All dimensions are measured from the floor to the top of the tank.

6,000L VHP Flow Chart

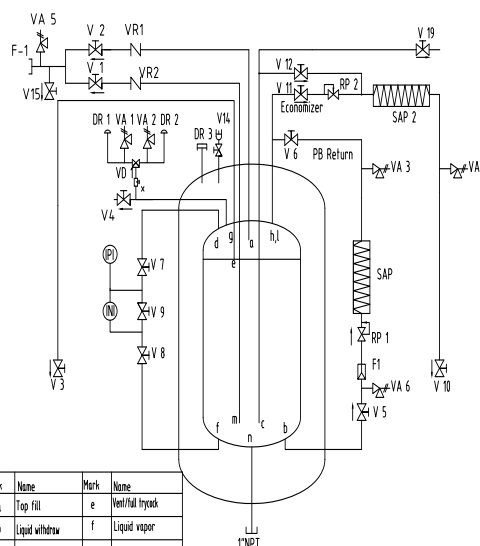

Mark	Name	Mark	Name
a	Top fill	e	Well/Full Inpack
b	Liquid withdraw	f	Liquid vapor
c	Liquid use	g	Safety
d	Gas vapor	h	PB out
i	Economizer	n	Liquid reserve
m	Bottom fill		

- Certification for medical Oxygen is available as an added option.
- CO₂ packages are available as an added option.

Please contact
Ratermann Mfg., Inc.
for additional information.

Rev: 12/12/18

TOP OR BOTTOM FILL? WHAT'S THE DIFFERENCE?



Ratermann Arctic Fox 6000L Top & Bottom Fill Tank

► **One of Ratermann Manufacturing's** Arctic Fox® tank, a highly functional micro-bulk tank that holds cryogenic gases such as liquid nitrogen. The Arctic Fox tank comes in 2,000, 3,000, and 6,000 liter sizes and is built to Ratermann Manufacturing's specification. Key features include a heavy duty galvanized pallet base, safe and easy access control valves, lifting lugs, content gauges, complete valve isolation package, and a high-quality mirror finish. The most unique feature is the top and bottom fill. This distinctive feature allows operators with a large cryogenic transport trailer to fill the Arctic Fox tank without stopping production, saving money and increasing efficiency. Numerous companies rely on Ratermann Manufacturing

Arctic Fox tanks to keep their business running smoothly.

► **Cryogenic tanks are** typically filled from the top using the blow down method. The blow down method is when the pressure of the tank is reduced by blowing out the head pressure of the tank in order to fill it. Blowing down a tank wastes product and in turn costs money. Top filling also requires taking the tank offline or to not be used while it is being filled because the tank can't keep pressure, which causes the customer using the tank to shut down and stop their operation during filling.

► **However, the Arctic Fox** tank enables the user to simultaneously fill from the top and bottom, eliminating

the need to use the less efficient blow down method. The bottom fill method keeps the pressure up, allowing the user to keep their equipment online and keeping their operation running since the Arctic Fox maintains the required pressure to keep operating. The top and bottom filling method does not require a tank to be blown down and therefore prevents loss of product during the filling process.

► **For customers such** as laser cutting facilities that use nitrogen gas in their machines to cut metal products, the Arctic Fox tank is invaluable as it permits operations and production to flow smoothly throughout the entire filling process. Because the top and bottom fill capability maintains the necessary pressure levels during the

WHY TOP FILL?

Top filling a tank requires the pressure of the tank to be reduced. In order to reduce the pressure in a tank the head pressure must be blown down or released from the tank. This wastes product. A tank must be taken off line and not in use while filling. This is the fastest way to fill but requires loss of product and stopping production of the equipment using the gas.



WHEN TO USE BOTH

Top and bottom filling at the same time combines the benefits from top filling and bottom filling. By filling top and bottom, the tank fills faster without needing to waste product by blowing down the head pressure and doesn't require the tank to go offline so machines using the gas can keep operating during filling.

WHY BOTTOM FILL?

Bottom filling does not require you to reduce the pressure of the tank. The tank can keep operating while being filled keeping equipment up and running. Bottom filling takes longer than top filling.

filling process, the user can continue production without halting the use of the gas. This ensures a seamless filling period for the customer unlike the process required by other tanks that rely on the top fill method.

► **Additionally, the Arctic Fox** tank features different hookup options. This flexibility allows multiple types of trucks to connect to fill the tank, including conventional micro bulk trucks with a standard cryogenic hose and those with an inch and a half bulk hose. This way, users aren't limited in what kind of trucks they can use to fill their tanks.

► **Throughout the entire** process, the operator has complete control over the pressure of the Arctic Fox tank. With top and bottom filling capability, filling is much faster than any other method. And users can complete rapid tank fills without the use of specialized proprietary pumping equipment. The Arctic Fox tank was designed for filling to be a seamless and efficient process.

► **With the Ratermann Manufacturing** Arctic Fox tank you will be able to maximize both production and

efficiency while minimizing costs to your customer's company. The Arctic Fox tank's top and bottom fill feature and dual blow down vents ushers in a smarter, faster and overall more efficient way to fill tanks allowing companies to fill tanks faster and make more deliveries per day.

► **Contact Ratermann Manufacturing** today to see how the Arctic Fox tank can set you apart from the competition and take your business to the next level.

ARCTIC FOX[®]

Cryogenic Tanks

ARCTIC FOX[®]

The Arctic Fox Tank is functionally and aesthetically designed and suited to serve virtually any cryogenic application, from Semi-conductor fabrication to Metal fabrication. The Arctic Fox Tank has many advanced features designed in a compact attractive package.

Tank Sizes: **1500L / 2000L / 3000L / 6000L**

See all the features at rmimfg.com/cryogenic-equipment

